

## D04FM

### Pressure Reducing Valve

#### Product specification sheet

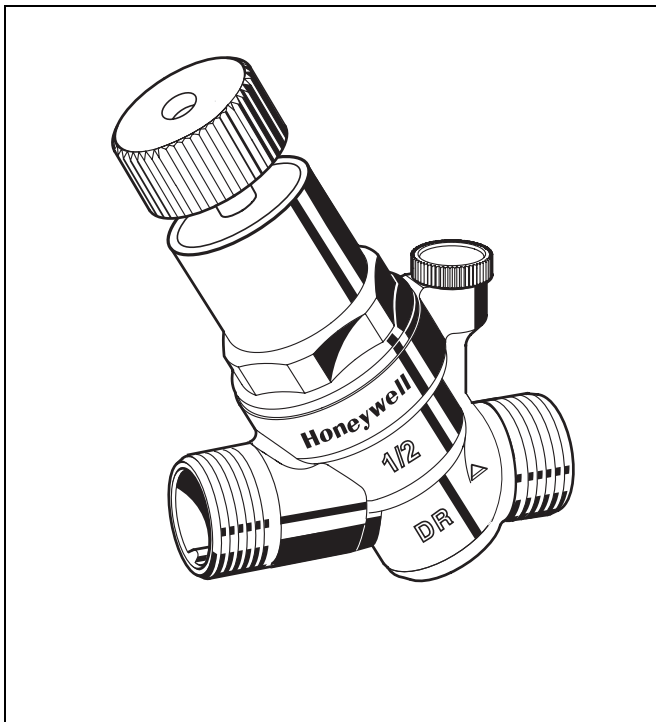

#### Construction

The pressure reducing valve comprises:

- Housing with pressure gauge connection G1/4"
- Spring bonnet with adjustment opening
- Green adjustment knob
- Adjustment spring
- Valve insert complete with diaphragm and valve seat
- Pressure gauge not included (see accessories)

#### Materials

- Dezincification resistant brass housing
- High-quality synthetic material valve insert
- High-quality synthetic material spring bonnet
- Spring steel adjustment spring
- Fibre-reinforced EPDM diaphragm
- EPDM sealing

#### Application

Pressure reducing valves of this type protect household water installations against excessive pressure from the supply. They can also be used for industrial or commercial applications within the range of their specification.

By installing a pressure reducing valve, pressurisation damage is avoided and water consumption is reduced.

The set pressure is also maintained constant, even when there is wide inlet pressure fluctuation.

Reduction of the operating pressure and maintaining it at a constant level minimizes flow noise in the installation.

#### Special Features

- DVGW approved according to DIN EN1567 (pending)
- WRAS approved according to BS EN1567 (pending)
- Compact construction
- The adjustment spring is not in contact with the potable water
- Outlet pressure adjustable with green adjustment knob
- Inlet pressure balancing - fluctuating inlet pressure does not influence outlet pressure
- Meets KTW/W270, WRAS and ACS guidelines for potable water

#### Range of Application

Medium	Water
Inlet pressure	max. 16 bar
Outlet pressure	1.5-6 bar adjustable

#### Technical Data

Installation position	Horizontal and vertical installation position possible In vertical installation position spring bonnet with adjustment knob facing upwards
Operating temperature	max. 40°C accord. to DIN EN 1567 max. 70°C (max. operating pressure 10 bar)
Minimum pressure drop	1 bar
Connection size	3/8", 1/2", 3/4"

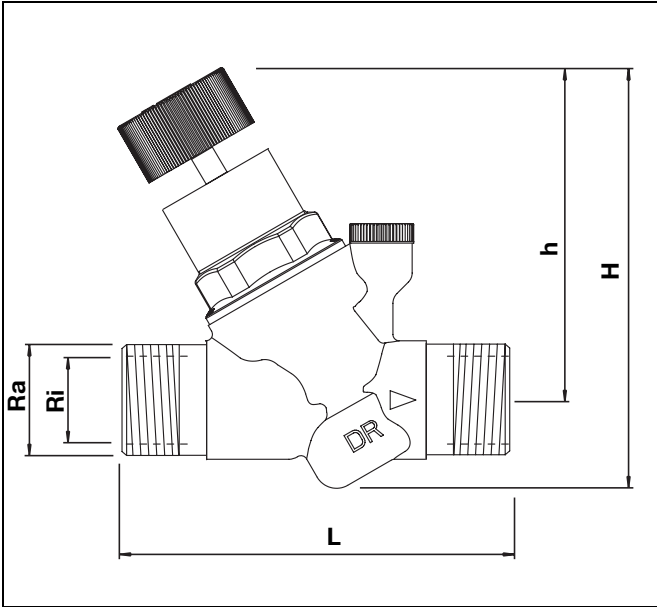

**Method of Operation**

Spring loaded pressure reducing valves operate by means of a force equalising system. The force of a diaphragm operates against the force of an adjustment spring. If the outlet pressure and therefore diaphragm force fall because water is drawn, the then greater force of the spring causes the valve to open. The outlet pressure then increases until the forces between the diaphragm and the spring are equal again.

The inlet pressure has no influence in either opening or closing of the valve. Because of this, inlet pressure fluctuation does not influence the outlet pressure, thus providing inlet pressure balancing.

**Options**

D04FM-     A =External thread on in- and outlet  
Connection size

Connection size	Ri	3/8"	1/2"	3/4"
	Ra	3/4"	3/4"	1"
Nominal size diameter	DN	10	15	20
Weight	kg	0,30	0,32	0,36
Dimensions	mm			
	L	84	84	88
	h	82,7	82,7	82,7
	H	106	106	106
DIN/DVGW Registration No.		requested		
WRAS Approval No.		requested		

**Accessories**

**M38K Pressure gauge**

Housing diameter 50 mm, below connection thread G1/4". Ranges: 0 - 4, 0 - 10, 0 - 16 or 0 - 25 bar.  
Please indicate upper value of pressure range when ordering

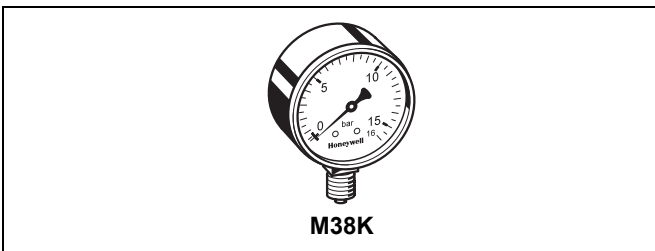

**Spare Parts**

No.	Description	Dimension	Part No.
1	Valve insert complete	3/8" - 3/4"	D04FMA-1/2
2	Blanking plug with O-ring	R1/4"	S06K-1/4
		(5 pcs.)	

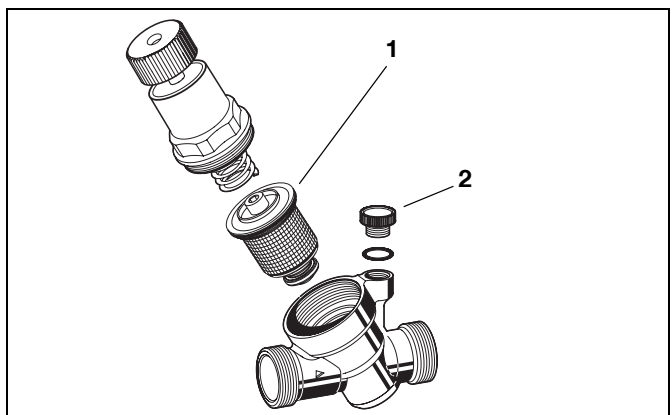

**Automation and Control Solutions**

Honeywell GmbH  
Hardhofweg  
74821 MOSBACH  
GERMANY  
Phone: (49) 6261 810  
Fax: (49) 6261 81309  
<http://ecc.emea.honeywell.com>

Manufactured for and on behalf of the Environmental and Combustion Controls Division of Honeywell Technologies Sàrl, Z.A. La Pièce 16, 1180 Rolle, Switzerland by its Authorised Representative Honeywell GmbH

EN0H-1054GE23 R1113  
Subject to change without notice  
© 2013 Honeywell GmbH

